

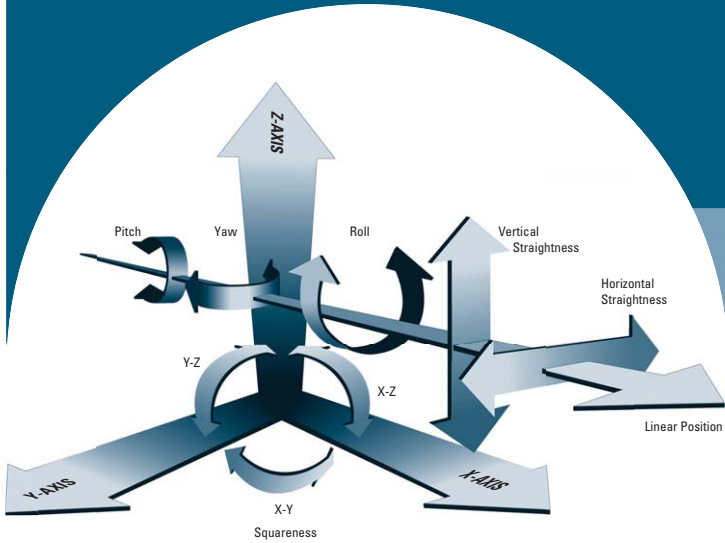

Agilent 5530

# Dynamic Calibrator

Verify Machine Performance with the World Standard for Laser-based Metrology



- Maximize CMM and Machine Tool Performance
- Improve Process Control and Reduce Costs
- Certify Machine Tool Accuracy

Our measure is your success.



# Agilent 5530 Dynamic Calibrator – A Powerful, Portable Laser-based Machine Tool Calibration System

## Overview

Accuracy and peak performance are keys to competitive success in today's lean factory environment. Your customers are asking for tighter tolerances and reduced costs. You want to control shop operations, reduce scrap and re-work and improve productivity. Meeting these challenges means that you need to maximize the performance of your machine tools and, as a result, machine tool calibration has never been more important.

For more than four decades, Agilent calibrators have set the standard for laser-based metrology systems used to calibrate and verify machine tool and CMM accuracy. We introduced the first dynamic calibrator and continue to offer industry leading performance.

Users benefit from improved process control and efficiency that help to optimize shop operations and reduce overall production cost. And, the powerful measurement capability of Agilent's NIST traceable Dynamic Calibrator enables manufacturers to conform to key international standards. The Agilent 5530 Dynamic Calibrator is the ideal measurement tool to help manufacturers improve process control and efficiency for CMM and machine tool operations.

### A powerful system that

- Measures machine tool positioning accuracy
- Provides compensation data used to correct machine positioning error
- Aids in diagnosing geometry problems
- Documents machine performance in eight international standards
- Provides production managers with known performance for each machine



Agilent 5530 Dynamic Calibration System  
(User PC required, optics and fixtures not shown)

## Verify Machine Performance and Improve Process Control

Customers continue to make demands on machine shops for more precise parts, manufactured to tighter specs. In order to maintain low inventories and trim cash flow, manufacturers want quick turnaround on parts. Short part runs, often using expensive materials, have become more common.

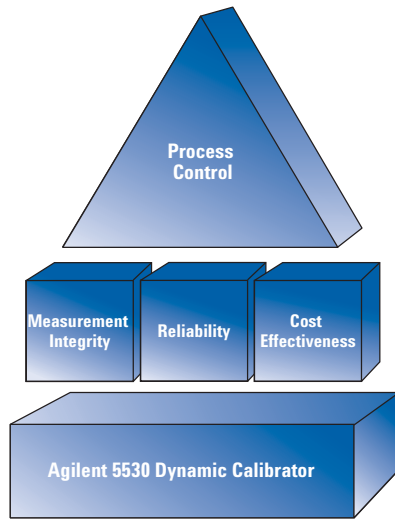

The 5530 Dynamic Calibrator provides the building blocks needed to improve process control.

To help machine shops succeed in this increasingly competitive environment, Agilent Technologies designs and manufactures the 5530 Dynamic Calibrator with unmatched repeatability and reliability, making it the most cost-effective laser calibrator available.

### Regular calibration with the 5530

- Provides verification of your machine tool's performance for manufacturers who want proof of quality.
- Helps you achieve process control by giving you a complete understanding of each of your machine's capabilities.
- Improves your shop's productivity by saving hours of CNC programmer time that would otherwise be spent adjusting the program to bring parts into spec.

The building blocks you need to improve process control and reduce costs allow you to:

- Improve machine performance
- Meet the most demanding design and tolerance specifications
- Reduce scrap and re-work
- Decrease trim waste
- Lower overall cost of shop operations

### Applications

- CMM Calibration
- Machine Tool Calibration
- Machine Certification

### Key Benefits

- Highest accuracy available
- NIST Traceable measurement tool
- Designed for portability
- Unmatched laser reliability and lifetime

## Small, Light Weight Electronics and Sensors

### A flexible, modular system

The Agilent 5530 Dynamic Calibrator is designed with the flexibility to meet your system's unique calibration requirements. The basic system includes the air and material sensors, cables, USB sensor hub, USB axis module, linear measurement kit, laser and tripod. Precision optics, designed for each individual measurement application are available to complete the system.



**Small and light weight, the Agilent E1735A USB Axis Module allows users to interface the laser, remote control, and optional A Quad B input cable to any PC.**



**Sensor cables have easy snap-on connectors so users can quickly change cable lengths as needed.**



**The Agilent E1736A USB Sensor Hub gives users the ability to connect up to four sensors to a PC.**

### The 5530 Laser Measurement System includes

Laser (0.7 m/s)	5519A
Laser Head Cable (7 m)	10882B
Remote Control	10888A
Linear Measurement Kit (includes optics and hardware)	55280B
USB Axis Module	E1735A
USB Sensor Hub	E1736A
Air Sensor (1)	E1738A
Material Sensor (1)	E1737A
Sensor Cable 5m (1)	E1739A
Sensor Cable 15m (1)	E1739C
Transit case for laser, sensors, USB modules and optics	E1734A
Tripod with mounting base	10753B
Transit case for Tripod	E1734B

### Available options:

Laser (1 m/s)	5519B
Angular Position Measurement Kit	55290A
Angular Position Measurement Kit	55290B
Sensor Cable 5m	E1739A
Sensor Cable 10m	E1739B
Sensor Cable 15m	E1739C
Sensor Cable 25m	E1739D

## Agilent Lasers — Proven Technology and Innovation Together in a Single Solution

The heart of the system is the Agilent 5519A/B laser. Offering unsurpassed reliability and stability, it is industry recognized for performance and accuracy. With more than 50,000 hours mean-time-between-failures (MTBF), the laser has the longest life-time available.

### Measurement integrity – results you can trust

At Agilent Technologies, we know that an incorrect measurement is worse than no measurement at all. Our two-frequency laser-based dynamic calibrator system is far less sensitive to air turbulence noise than single-frequency systems. As a

result, the 5530 Dynamic Calibrator is less sensitive to thermal gradients in the air and you can have complete confidence in the repeatability of your measurements. Even when temperatures in your shop are unstable and air quality is poor, you'll be able to repeat your measurements and get consistent results.



**Agilent 5519A/B Laser is a dual-frequency laser that enables the inherent repeatability of two-frequency interferometer calibration.**

---

## A Leader in Precision Optics for More than 35 Years

Agilent is a world leader in the design and fabrication of precision optics. The accuracy of your measurement depends on the optical components in the interferometer and reflectometer. We offer a wide selection of optics to meet your specific requirements for making linear, diagonal, angular, angular position, flatness and way straightness, straightness and parallelism, squareness, and time based measurements. In addition, both of Agilent's Rotary Axis Kits combined with the Angular Optics Kit gives you the ability to make angular position measurements.

### Optics built for the shop environment

Further enhancing the integrity and reliability of measurements, Agilent calibration optics are built to be rugged and thermally stable in order to withstand the rigors of a manufacturing environment. The interferometer and reflectometer optics are encased in stainless steel housings to reduce the effects of temperature changes that cause other metals to contract and expand at a higher rate. As a result, measurements made with optics in stainless steel housings are more accurate and more repeatable. The rugged qualities of stainless steel also work to increase the optics lifetime, even when they are subjected to abuse.

### Equipment required to make different measurement types

Basic 5530 Dynamic Calibrator Laser Measurement System plus:

Measurement Type	Supplemental Kit Required	Model Number
Linear	Linear Measurement Kit [included with the 5530 system]	55280B
Diagonal	Diagonal Measurement Kit Linear Measurement Kit [included with the 5530 system]	10768A 55280B
Angular	Angular Optics Kit	55281A
Rotary/Indexing Table Calibration	Angular Position Measurement Kit Supplemental Fixturing Kit Angular Optics Kit	55290A OPT. 744 55281A
Rotary/Indexing Table Calibration	Angular Position Measurement Kit Supplemental Fixturing Kit Angular Optics Kit	55290B OPT. 744 55281A
Flatness and Way Straightness	Flatness Accessory Kit Angular Optics Kit	55282A 55281A
Straightness and Parallelism	Straightness Measurement Kit	55283A
Squareness	Optical Square Straightness Measurement Kit	10777A 55283A

\* Please go to [www.agilent.com/find/machinetoolcalibrator](http://www.agilent.com/find/machinetoolcalibrator) for detailed information about kit contents

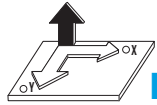

## Linear Measurements

Linear measurements are made at multiple points along a machine's travel path to measure linear displacement and velocity.

### Purpose of measurement

To document capability and, when possible, improve positioning accuracy along an axis for any machine that requires positioning accuracy and velocity control through a compensation table.

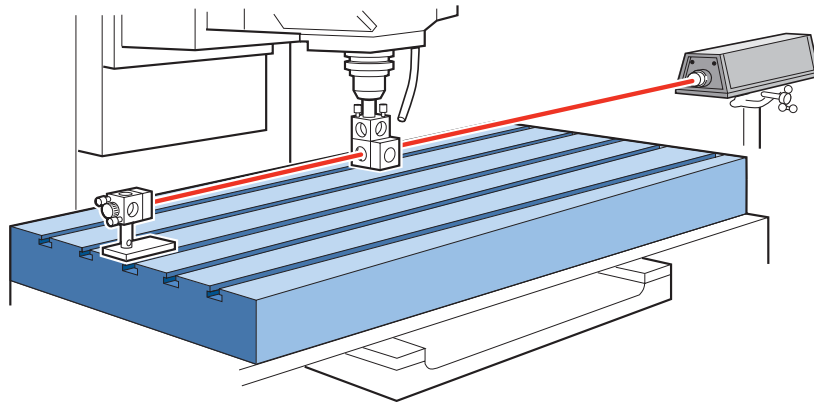

Optical setup for linear measurements

### Additional capabilities

- Long-range option doubles measurement range to 80 m (Option C01 for 5519A).
- For up to 1m/s axis velocity, replace 5519A with 5519B.
- 0.25 nm resolution with high-resolution plane mirror optics.
- Perform surface (2-D) diagonal measurements.
- High data rate/fast data collection is useful for relative vibration analysis or for measurements made "on-the-fly".
- Long-term thermal drift test can be performed over hours or days, showing possible effects of temperature on geometry.

### Basic equipment

Basic Laser System 5530  
Linear Measurement Kit 55280B  
included with 5530

### Also recommended

Second Material Sensor E1737A  
Sensor Cable (5m, 10m, 15m, 25m)  
E1739A/B/C/D  
Fixturing Kit 10744A

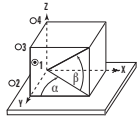

## Diagonal Measurements

Diagonal Measurements are linear measurements made on the four body diagonals of a machine's working volume to check for volumetric positioning performance.

### Purpose of measurement

To document machine tool capability and quickly perform a complete check of volumetric positioning performance.

### Additional capabilities

Long-term drift tests can be performed over hours or days showing possible effects of temperature on geometry.

### Repeatable signature

To achieve a signature for each of your machine tools, make diagonal measurements with the 5530 and the Diagonal Measurement Kit. The repeatability of diagonal measurements is optimized because the laser beam is aligned to the machine rather than the machine to the laser by changing the machine program. By using the identical machine movement for each set of measurement, you learn if the machine meets spec and you can predict change in performance even when volumetric performance is adequate.

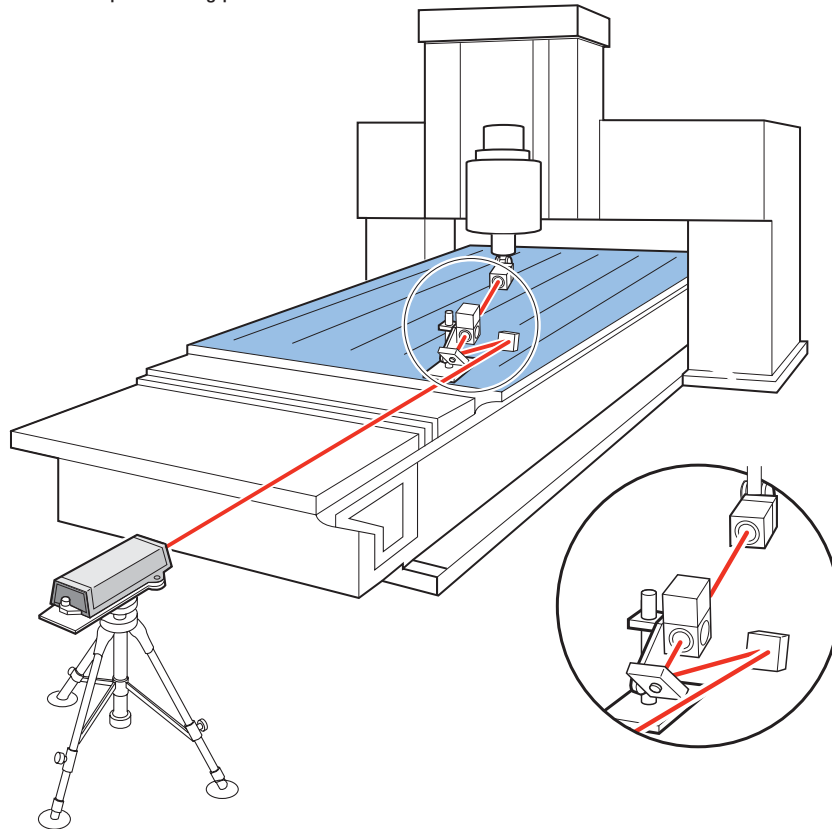

### Basic equipment

Basic Laser System 5530  
 Linear Measurement Kit  
 included with 5530  
 Diagonal Measurement Kit 10768A

### Also recommended

Second Material Sensor E1737A  
 Turning Mirror 10769B  
 Lightweight Reflector 10767B  
 Fixturing Kit 10744A

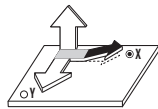

## Angular Measurements

Angular measurements are made at multiple points along a machine's travel path to test for rotation about an axis perpendicular to the axis of motion (pitch and yaw).

- A common cause of machining errors, geometry errors are as critical as linear positioning errors.

- Unwanted angular motion in machine tools causes positioning errors that reduce the overall accuracy of your machine.

### Purpose of measurement

To document, analyze and diagnose machine tool geometry.

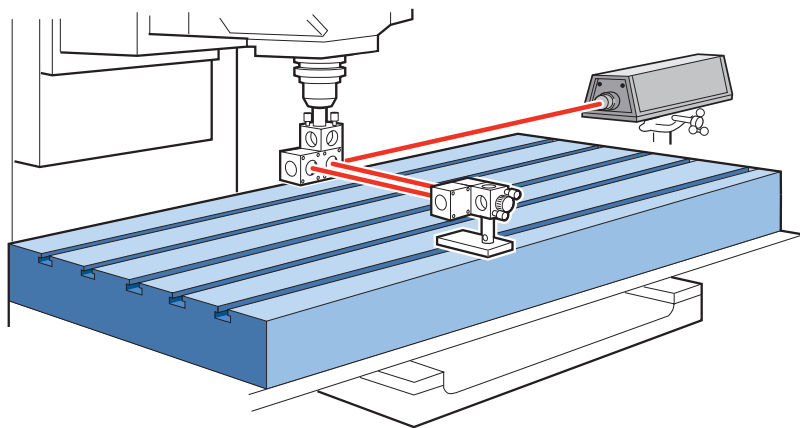

Optical setup for a yaw measurement on Y-axis

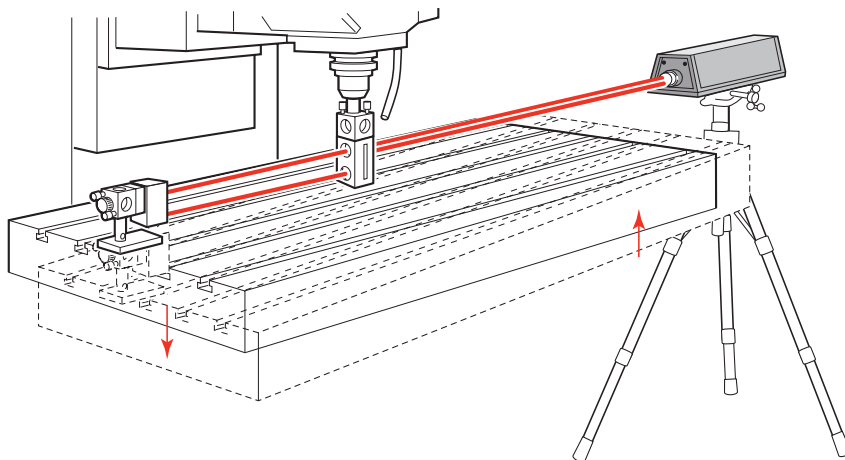

Table pitch along X-axis

### Additional capabilities

- Positioning errors over the work zone can be estimated from the angular and linear measurements.
- The condition of ways and the range of squareness and parallelism in the work zone can be indicated by angular measurements.
- Angular measurements help find the causes of linear positioning errors and can be useful in making decisions about whether to replace or rebuild older machines.
- Long-term drift tests can be performed over hours or days, showing possible effects of temperature on geometry.

### Basic equipment

Basic Laser System 5530  
Angular Optics Kit 55281A

### Also recommended

Fixturing Kit 10744A

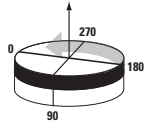

## Angular Position Measurements

Angular position measurements are made on full, multiple or partial rotation of rotary tables, indexing tables and other angular positioning devices.

Agilent offers two Angular position measurement solutions. The 55290A offers greater automated precision. The 55290B is an economical solution that does not require the machine to lift the optics during rotary motion.

### Purpose of measurement

To document machine tool capability and even improve angular positioning accuracy when possible.

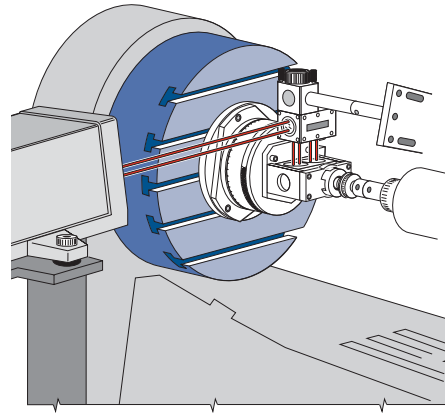
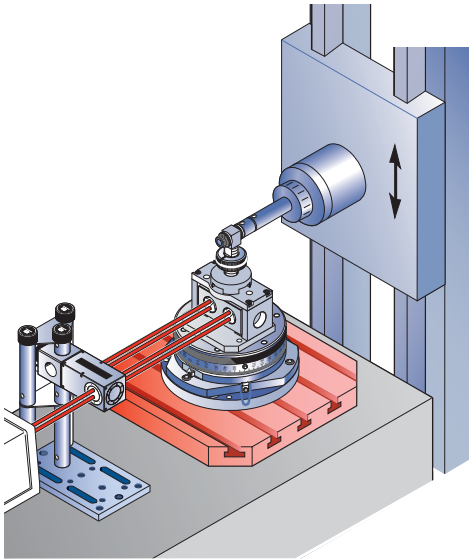

**55290A Optical setup on horizontal machining center with vertical table (right) and with horizontal table**

### Basic equipment

Basic Laser System 5530  
 Angular Optics Kit 55281A  
 Angular Position Measurement Kit  
 55290A or 55290B  
 Supplemental Fixturing Kit  
 55290A/B, Option 744

### Also recommended

Fixturing Kit 10744A (can replace  
 Supplemental Fixturing Kit  
 55290A/B, Option 744)

### Additional capabilities

- The Angular Position Measurement Kit enables users to keep the laser beam on indexing tables, even those that require a great deal of lift – up to 15 mm.
- Long-term drift tests can be performed over hours or days.
- Agilent Technologies' equipment can calibrate tools that cannot rotate 360°. The Agilent Angular Position Measurement Kit comes calibrated for any arc.
- Can perform multiple revolutions when used on turning centers with "C" axis spindles that are programmed to index to specific angles as well as continuous revolutions.

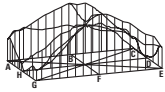

## Flatness and Way Straightness

Flatness measurements are a series of angular measurements made along a pattern of lines combined to evaluate the flatness of a surface in three dimensions.

Way straightness measurements are a series of angular measurements made in a single line along a machine's ways to evaluate the straightness of those ways in two dimensions.

### Purpose of Flatness measurement

To document and analyze in 3-D any flat surface such as a surface plate or machine bed.

### Purpose of Way Straightness measurement

To document and analyze straightness of a line along a solid object such as machine tool ways and master straight edges. This measurement is very useful when you are setting up or rebuilding machines.

### Basic equipment

Basic Laser System 5530  
Angular Optics Kit 55281A  
Flatness Accessory Kit 55282A

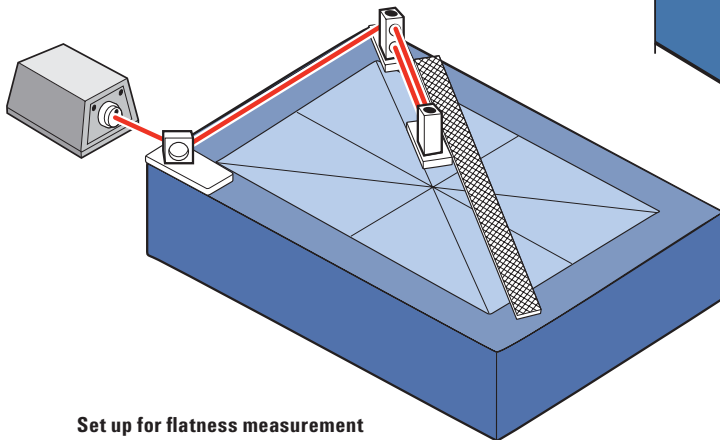

Set up for flatness measurement

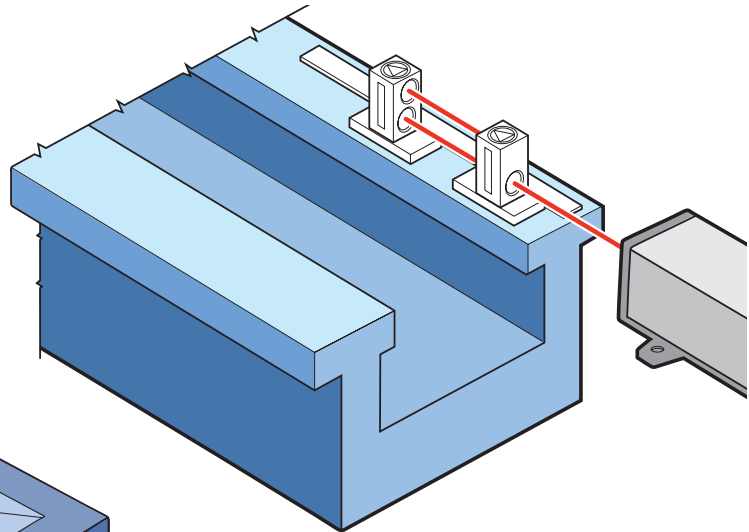

Machine way straightness measurement

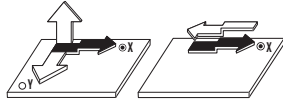

## Straightness and Parallelism

Straightness and parallelism measurements identify geometry errors that seriously degrade machine tool performance including straightness of travel and parallelism of co-linear axes.

Straightness measurements evaluate the unwanted side-to-side or up-and-down motion of a machine tool's travel in a specified direction.

Linear parallelism measurements evaluate the misalignment between two co-linear axes such as a w-axis and z-axis on a horizontal machining center.

Rotational parallelism measurements evaluate the misalignment between a rotational axis and a linear axis such as spindle parallelism of a turning center.

Straightness of travel, a measurement that is particularly sensitive to air turbulence, is accurately measured using Agilent's two frequency laser optical "straight edge" that is less sensitive to air turbulence than other laser technologies.

### Purpose of measurement

To document, analyze and diagnose machine tool travel and parallel axes of motion.

### Additional capabilities

Long-term drift tests can be performed over hours or days to diagnose machine problems.

### Basic equipment

Basic Laser System 5530  
 Straightness Measurement Kit 55283A (includes 10774A Short Range Straightness Optics to measure distances up to 3 meters [120 inches])

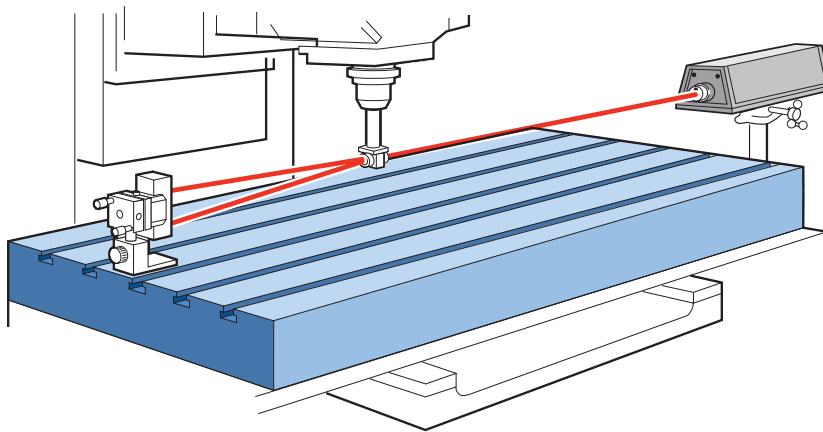

Optical setup for vertical straightness along the X-axis

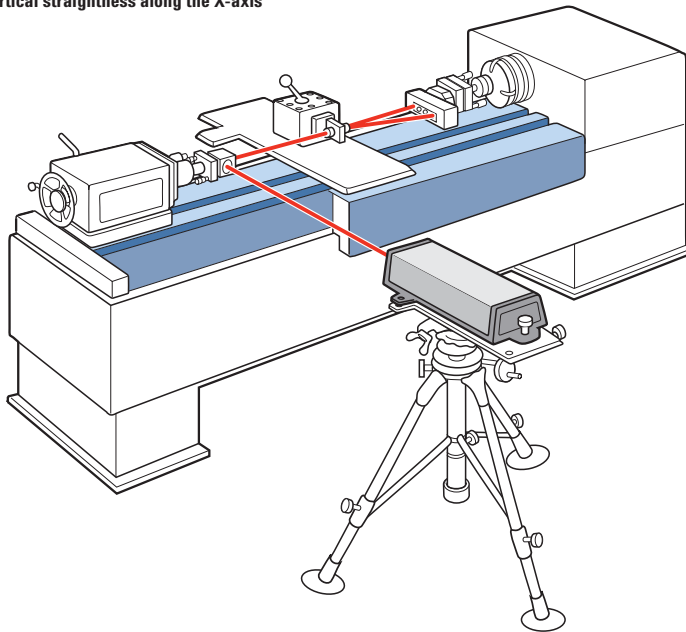

Optical setup on lathe for parallelism

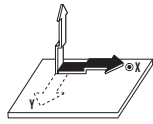

## Squareness

Squareness measurements are made in a horizontal or vertical plane to determine if two machine axes are oriented and move perpendicular to each other. Out-of-squareness between axes, a machine tool geometry error can seriously degrade machine tool performance.

### Purpose of Squareness measurements

To document, analyze and diagnose out-of-squareness of orthogonal machine axes.

### Additional capabilities

- Long-term drift tests can be performed over hours or days showing possible geometry problems caused by changing thermal gradients.
- Perform straightness and Squareness measurement of two orthogonal axes with one optical setup.

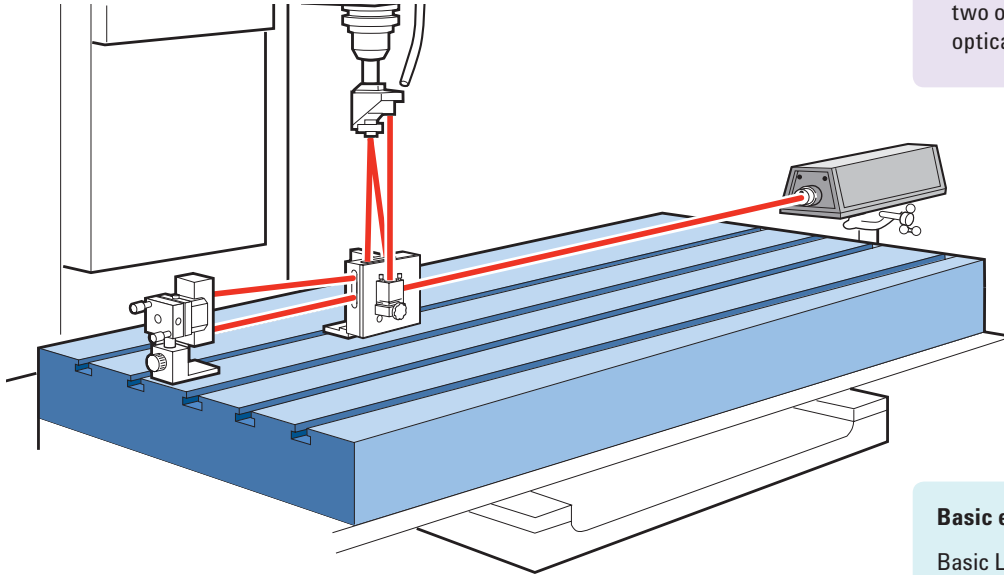

Optical setup for XZ squareness

### Basic equipment

Basic Laser System 5530  
Straightness Measurement Kit 55283A  
Optical Square 10777A

### Also recommended

Long Range Straightness Optics  
10775A (measures distances  
up to 30m)

## Software Tools Make the Most of Your Data – In Just Six Steps

Agilent gives you the tools to make a difficult task easier. Windows®-based software allows you to navigate through the measurement process, one step at a time. After this powerful PC software helps you make the measurement and collect the data, it analyzes and plots the data so you can build a machine history and gain a solid understanding of your processes. Logical graphics guide the user through five steps to make a measurement. The sixth step calculates error compensation for input to the CNC so that any needed corrections can be made.

### Six steps to calibrate

1. Select a measurement  
Select a measurement from the main menu or recall previously saved data and setup information.
2. Set up the laser  
Select the measurement axis.  
Align the optics.
3. Set up measurement  
Enter target list and trigger mode or recall setup from a previous calibration (from Step 1).
4. Collect the Data  
Collect data manually, automatically or by encoder
5. Analyze the Data  
Analyze data in any of eight international calibration standards.
6. Compensation table  
Error compensation tables are calculated and printed, ready for input to the CNC.

### Online “Help” windows

Technicians and engineers of all skill levels value the online “help” sources available at every step in the calibration process to provide fast answers about a specific screen or subject. Online measurement checklists and setup graphics help new users avoid mistakes and omissions. Additional help is available in the manuals. Help windows as well as manuals are translated into eight different languages.

### Proven software

The 5530 uses the same software as Agilent’s earlier dynamic calibrator products making it easy for current customers to move to the new system and providing assurance to new users that the software is reliable and offers the data that they need.

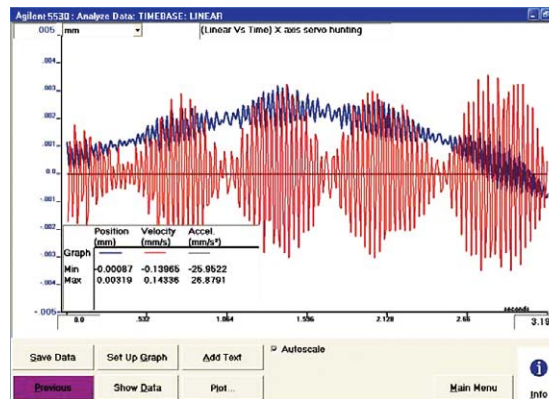

Servo hunting with position data

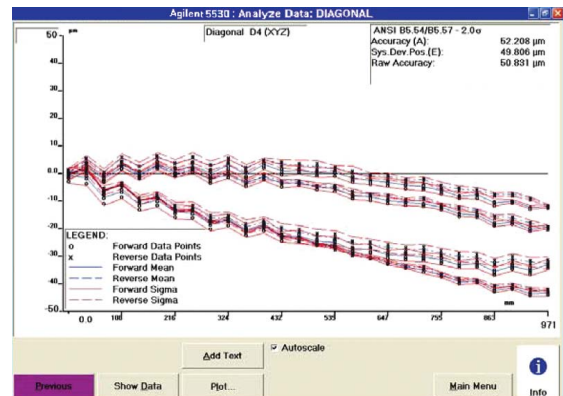

Agilent diagonal measurements provide a signature that tells if your machine performance has changed

## Supplemental Fixturing Kits

### 55290A/B – Opt. 744 Supplemental Fixturing Kit

- 2 Gusset
- 3 Post (~2")
- 4 Post (~4")
- 1 Base (large)
- 1 Flexible Ball Joint
- 1 Height Adjuster with Knob and Thumb Screws



Supplemental Fixturing Kit 55290A/B – Opt. 744

### 10744A Supplemental Fixturing Kit

The Fixturing Kit 10744A is a rigid structure that helps you calibrate in the center of your work zone to avoid Abbe errors. The rigidity eliminates vibration related to fixturing.

- 3 Gusset
- 2 Post (~1")



Supplemental Fixturing Kit 10744A

- 2 Post (~2")
- 5 Post (~4")
- 1 Base (large)
- 1 Adapter Plate
- 1 Flexible Ball Joint
- 3 Right Angle Clamp
- Hardware Kit with hex keys

---

## Upgrade Kits for Current System Owners

The laser and optics are a big part of the system. And, since Agilent makes the most reliable laser system available and the most rugged optics, you do not need to replace the entire system to get the improved performance offered by the 5530. Customers who already own a complete Agilent Dynamic Calibrator have several economical upgrade options available that allow you to extend the life of your investment and increase the overall accuracy of your system.

Talk to your local distributor for more information.

## Machine Tool Manufacturers

Machine tool manufacturers use the 5530 Dynamic Calibrator to:

- Respond to customer requests for acceptance testing at installation.
- Avoid expensive troubleshooting at the customer site by ensuring all machines meet specifications before they leave the factory.
- Give customers documented performance of their equipment as it leaves the factory by merely hitting a button on the screen. In any of eight languages. To key international standards and NIST traceable.
- Monitor and control the building process by recording the capability of every machine produced.

- Identify performance errors and make improvements in machine tool design.
- Reassure customers that their machine has passed the test of the toughest laser calibrator – the 5530 heterodyne laser interferometer that is the most rugged and accurate calibration method available.

For machine tool manufacturers who provide their customers with regular calibration service, the 5530 fits into a single transit case. When needed the tripod comes in its own wheeled transit case that can piggy back on the system case.



---

## When Should You Calibrate?

The 5530 Dynamic Calibrator helps you control quality and maximize productivity from the day your machine tool is delivered:

### 1. Acceptance Testing:

Machine tool manufacturers carefully test your equipment for accuracy before it leaves the factory, however equipment often loses accuracy during shipment and installation. By calibrating with the 5530 Dynamic Calibrator, you prevent costly performance problems and ensure that your new investment begins paying its way immediately.

### 2. Scheduled Calibration:

Just as regular maintenance increases the life of your automobile, periodic calibration increases the life of your machine tool. Agilent Technologies recommends that new machine tools be calibrated every six months during the first year-and-a-half of operation and then annually, unless calibration results warrant more frequent calibration. If environmental factors are extreme or if the machine tool is subjected to high stress or a crash, users should calibrate at shorter intervals.

Scheduled calibration with the 5530 provides a complete picture of your machine tool performance so that you can efficiently schedule work flow. You can schedule the most demanding work on the most accurate machines. And by identifying machines that cannot meet the accuracy requirements for a given job, the 5530 helps you control your processes so you avoid costly scrap and schedule slips.

### 3. Quick Check:

Measuring diagonals is a quick way to verify machine tool volumetric performance and check a machine's signature. If the diagonal measurements are acceptable, a full calibration and its associated downtime may be avoided.

### 4. Diagnosis of problems:

When a crisis occurs and your machine begins producing scrap, the 5530 can minimize the time it takes to get your process back on track. Data collected during this troubleshooting process can be compared with data that is collected and saved during regular, scheduled calibration to help pinpoint most problems.

### 5. ISO 9000 documentation:

The Agilent Technologies laser is an important tool to help you verify and document your manufacturing process as may be required for ISO 9000 certification. Plots showing machine performance can be used for documented proof of performance.

**Agilent Technologies Laser-based Metrology Systems**

Agilent Technologies offers modular laser interferometry solutions for a wide variety of precision measurement applications ranging from machine tool calibration to photolithography. Our proprietary laser technology offers exceptional stability and reliability. Together with our high-precision optical design and manufacturing capability we provide industry-leading metrology tools customers can count on.

More information about Agilent's Nano Positioning Metrology products is available at [www.agilent.com/find/lasers](http://www.agilent.com/find/lasers) or by contacting one of our offices or your local distributor.

**For more information about Agilent Dynamic Calibrators:**

Learn more:  
[www.agilent.com/find/lasers](http://www.agilent.com/find/lasers)

Find an Agilent customer center in your country:  
[www.agilent.com/find/lasers/contactus](http://www.agilent.com/find/lasers/contactus)

**Contact Us**

**USA**

Phone: USA Toll Free: +1.800.829.4444  
Email: [info\\_lasers@agilent.com](mailto:info_lasers@agilent.com)

**Canada**

Phone: Canada Toll Free: + 877.894.4414  
Email: [info\\_lasers@agilent.com](mailto:info_lasers@agilent.com)

**Europe**

Phone: +31 (20) 547-2160  
Email: [info\\_agilent@agilent.com](mailto:info_agilent@agilent.com)

**Japan**

Phone: +81 426 56 7832  
Email: [contact\\_japan@agilent.com](mailto:contact_japan@agilent.com)

**Latin America**

Phone: +1.305.269.7500  
Email: [info\\_lasers@agilent.com](mailto:info_lasers@agilent.com)

Product specifications and descriptions in this document are subject to change without notice.

The Agilent 5530 Dynamic Calibrator comes with a three-year warranty. An optional two-year extension is available for purchase, providing a total of five-years of warranty coverage.

This information is subject to change without notice.  
© Agilent Technologies, Inc. 2008  
Printed in U.S.A. July 31, 2008  
5989-9354EN

**Contact your local Agilent Distributor**

